



DELTA
Two-Way Radio



DS 555
User Manual

DELTA RADIO GROUP
www.deltaradiogroup.com

Thanks

Thank you for choosing **DELTA** DMR Digital Radio, we believe it is a wise choice to choose us because we have the latest technology, the most stable components, the most advanced production technology. **DELTA** radio will provide you with the reliable performance and high quality you demand.

This user manual apply to: DELTA DS555

Safety Instruction

Please observe the following safety tips to prevent fire, accidents, personal injury or equipment damage.

- ▶ **Do not** modify the radio or its charger in any way.
- ▶ **Do not** expose the radio to direct sunlight for extended periods of time, leave near heaters or other heat sources.
- ▶ **Do not** store or use unprotected radios for prolonged periods in areas of high dust or excessive moisture.
- ▶ Users may experience signal interference if the unit is used near devices such as TV or electric generators.
- ▶ If the unit emits smoke or you notice a strange smell, immediately turn off the power, and send it to the closest repair service station.
- ▶ The radios are small but contain high power components. It is not uncommon to notice slight warming of the handset. This is normal and the unit may continue to be used.

If there is any problem with the unit, please contact DELTA or your local distributor.

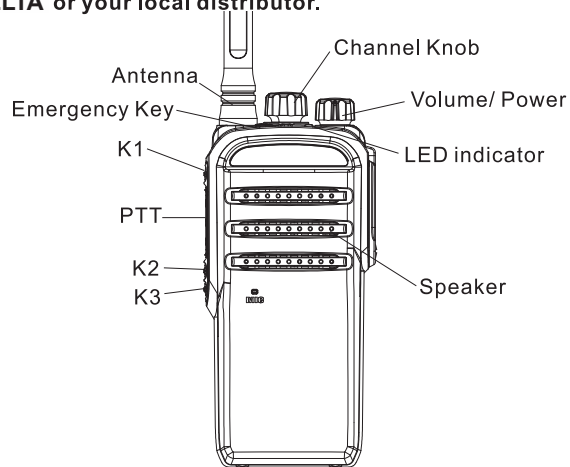

Turn on

Turn the Volume/Power knob clockwise to turn the radio on.
(Some radios are programmed to emit a tone when powered on).

Turn off

Turn the Volume/Power knob counter clockwise to turn the radio off, you will hear a sound when the radio is turning off.

Volume adjustment

Press and hold down the squelch key off momentarily to hear the continuous beep and turn the volume/power knob to adjust.

Three way to choose channel

1. Channel knob: rotate the "channel control" to choose the needed channel.
2. Channel button: choose the channel you need.

Transmit and receive

Press PTT button, the radio will enter the transmit state, the red light will turn on, the LCD display (if equipped) will indicate transmit.

Release PTT button, the radio will enter the receive state, the green light will turn on when receiving voice / data, and the LCD display (if equipped) will indicate receive.

DELTA Radios Quality Warranty and Liability

The warranty range and limitation

DELTA is committed to quality and stands behind its products.

DELTA will, during the warranty period specified for each product, repair or replace components that fail as a result of poor workmanship or materials. This warranty does not cover improper use or intentional damage.

The warranty policy does not include the following conditions:

1. Defects or damages caused by working in abnormal or unusual situations.
2. Defect or damages caused by misuse, accident, or water submersion.
3. Defect or damages caused by unauthorized installation, repair, tampering or adjustment.
4. Warranty does not extend to cosmetic scratches or damages as a result of normal use or misuse.
5. This warranty is void if:
 - (a) the product information label on the back aluminum case is removed, or if the serial number is tampered with, changed, or cannot be identified.
 - (b) If the battery case is damage, tampered with, or unsealed.

General Items

This warranty policy establishes the liability limits for which

DELTA is responsible

DELTA has the right to decide, in their sole discretion, whether to repair, replace, or refund the purchase price of any equipment subject to this warranty. There are no other options available under this warranty. This express warranty is the complete agreement. **OTHER THAN AS EXPRESSLY SET OUT IN THESE TERMS OR ADDITIONAL TERMS, NEITHER ABELL NOR ITS SUPPLIERS OR DISTRIBUTORS MAKE ANY SPECIFIC PROMISES ABOUT THE SERVICES OR PRODUCTS.**

CONTENT

Unpacking and device check	1
Accessory	1
Battery information	2
Battery protection	2
Battery Usage	3
Battery charge	3
Preparation	4
Installing the battery	4
Assemble the antenna	4
Assemble the belt clip	5
Disassemble the belt clip	5
Insert the earphone	5
Function key	6
Charging the Battery	7
Charger Indicator	7
LED Indicator of Transceiver	7
Function and basic operation	8
Turning your radio on and off	8
Switch channel	8
Push-to-talk operation	8
Digital Channel Information	12
Time out timer(TOT)	12
Single call, Group call, All call	13
CTCSS/ CDCSS	13
Tail Tone Elimination	14
Power	14
Digital mode setting	15
Safty information	16

Unpacking and device check

Please take the radio out of the package carefully, and before disposing of the package material, we advise you to check the accessories according to the following list. If any part is lost or damaged, please request a claim latter from the shipper or supplier.

Accessories

Items	quantity
Antenna	1
Belt clip	1
Power supplier	1
Battery	1
Charger	1
Lanyard	1
Instruction manual	1
Warranty card	1



Antenna

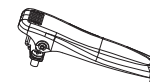

Belt clip



Lanyard

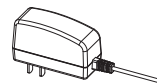

Power supplier



Charger



1800mAh
Li-ion battery

Battery information

Battery protection

DELTA radios use lightweight, environmentally friendly lithiumion batteries as a power source. The following battery tips will help you to get the best performance and prolong the battery life of your equipment.

1. Be sure to use the original DELTA charger to charge the battery.
2. When charging radios, please power off the radios to ensure battery can be fully and effectively charged.
3. New, uninstalled batteries can be stored for long period, but should be stored in a cool, dry place. (These should be recharged once every three months to maintain the battery's electrical properties, otherwise it will be damaged and will not function properly).
4. New batteries need to be fully charged before use.
5. Use only the battery charger and power supply specified by **DELTA** . Use of non-authorized charging systems will void the warranty of both the battery and the equipment.
6. Avoid extreme temperatures as this will effect capacity of the battery.
7. The battery cannot be stored in hot or cold places, otherwise it will reduce battery capacity and useful life. The battery should always be stored at normal temperature, and radios equipped with cold batteries may temporarily not work, even if fully charged.
8. Do not let the metal stripes on the battery come into contact with metal objects (such as metal benches, pins, etc) as this may cause the battery to short circuit.
9. Always dispose of old or damaged batteries In accordance with local recycling laws.
10. **NEVER** discard or expose batteries to fire, this will result explosion and serious injury or death.

Battery Usage

1. Do not use, install or attempt to charge damaged batteries.
2. Do not use batteries in any other equipment other than that which it is designed for.
3. Battery charging time varies and is determined by the remaining capacity of the battery and the battery and charger type. The battery can be repeatedly charged and discharged more than 300 times, but they will age with use. Aging will occur quicker when batteries are used for short periods and then recharged. Batteries should be allowed to fully discharge before charging to prolong battery life.
4. Batteries that are stored and unused discharge over time.

Battery charge

When the usage is very low, you can not use the radios.

1. The battery may be installed in the charger on the radio or alone. Please use the the provided charger power supply with the charger
2. The charger indicator shows the charge state:

Indicator	Current state
Red light flash	Waiting for charge
Red light glows	During charging
Green light glows	Charge complete

Preparation

Installing the battery

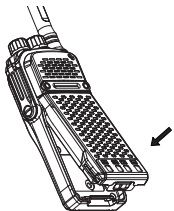

Assemble: Align the battery with the radio chassis, push forward and down until the battery clicks in place.

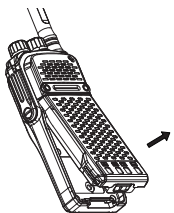

Disassemble: Lift battery catch on bottom of battery, lift up and pull away from chassis.

Assemble the antenna



Insert antenna's threaded connector into radio's antenna connector. Thread clockwise until snug. Do not over tighten

Assemble the belt clip

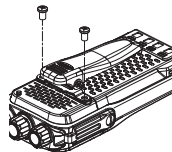

Assembly: Attach belt clip using the provided screws by aligning screws with threaded holes in chassis.

Disassemble the belt clip

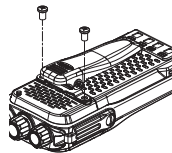

Disassemble: Unscrew the screws holding the belt clip and remove belt clip from chassis.

Insert the earphone

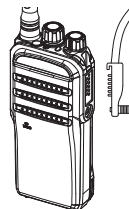

Open the rubber cover to insert the Earphone.

Function key

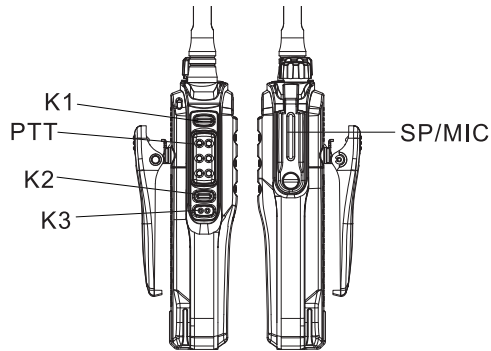
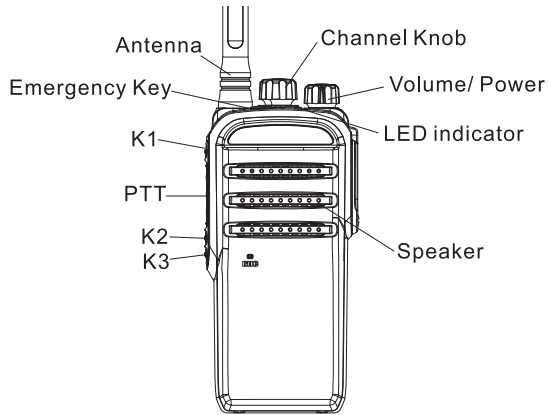

Charging the Battery

Use only the charger and battery specified by Delta. Charger LED can indicate the charging process.

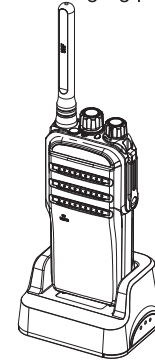

Charger Indicator

Indicator	Charge Status
Red flash	Standby
Red glows	Charging
Green glows	Fully charged

LED Indicator of Transceiver

Indicator	charge Status
Green glows 2-3S	Power-on cycle
Green glows	receiving signal
Green flash	received
Red glows	transmitting
Red flash	Battery low will be indicated by the red LED flashing and an audible beep. Please charge or replace the battery as soon as possible to ensure normal operation.

Function and basic operation

Turning your radio on and off

Power on: Turn selector (power switch / volume control knob) clockwise. Click will be heard when selector turns the radio on. If programmed, a power-on tone will be heard and the radio will enter the receive state.

Power off: Turn selector (power switch / volume control) counterclockwise until a click is heard. This indicates that the radio is powered off.

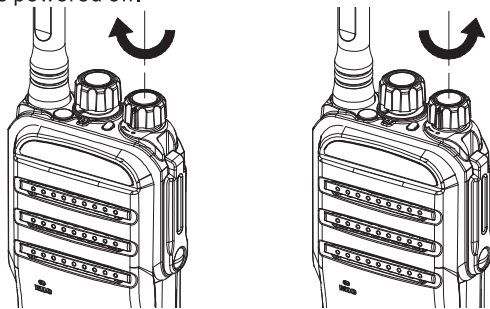

Switch channel

When you need to make a call on a specific channel, rotate the channel knob to the desired channel. If the channel broadcast function is enabled, the channel number will be announced locally. If a channel has not been populated via programming, a continuous tone will be heard from the radio.

Push-to-talk operation

Select the desired channel with the channel selector.

Transmit: Hold the radio in a vertical position approximately 2.0 cm (1.0 inches) from your lip. Press the PTT and speak.

Receive: The LED indicator will light green  when a signal is received and the speaker will emit audio. Adjust the volume control knob for a comfortable level."

Key		Functions
K1	Short Press	Non-functional; Emergency alarm; Cancel emergency alarm; Voice control; Power switch; Steady state monitoring [Simulation]; Steady cancel mute [Simulation]; Scanning; (DMR); one-click call 4 (DMR); broadcast local ID (number); broadcast channel number; broadcast power; broadcast battery power; broadcast channel type; area switching;
	Long Press	No function; emergency alarm; cancel emergency alarm; voice control; power switching; steady state monitoring [simulation]; transient monitoring [simulation]; steady state cancel squelch [simulation]; transient cancel squelch [simulation]; Network; One-key call 1 (DMR); One-key call 2 (DMR); One-key call 3 (DMR); One-key call 4 (DMR); Broadcast local ID (number); Broadcast channel number; Battery power; broadcast channel type; area switching;
K2	Short Press	Non-functional; Emergency alarm; Cancel emergency alarm; Voice control; Power switch; Steady state monitoring [Simulation]; Steady cancel mute [Simulation]; Scanning; (DMR); one-click call 4 (DMR); broadcast local ID (number); broadcast channel number; broadcast power; broadcast battery power; broadcast channel type; area switching;
	Long Press	No function; emergency alarm; cancel emergency alarm; voice control; power switching; steady state monitoring [simulation]; transient monitoring [simulation]; steady state cancel squelch [simulation]; transient cancel squelch [simulation]; Network; One-key call 1 (DMR); One-key call 2 (DMR); One-key call 3 (DMR); One-key call 4 (DMR); Broadcast local ID (number); Broadcast channel number; Battery power; broadcast channel type; area switching;
K3	Short Press	Non-functional; Emergency alarm; Cancel emergency alarm; Voice control; Power switch; Steady state monitoring [Simulation]; Steady cancel mute [Simulation]; Scanning; (DMR); one-click call 4 (DMR); broadcast local ID (number); broadcast channel number; broadcast power; broadcast battery power; broadcast channel type; area switching;
	Long Press	No function; emergency alarm; cancel emergency alarm; voice control; power switching; steady state monitoring [simulation]; transient monitoring [simulation]; steady state cancel squelch [simulation]; transient cancel squelch [simulation]; Network; One-key call 1 (DMR); One-key call 2 (DMR); One-key call 3 (DMR); One-key call 4 (DMR); Broadcast local ID (number); Broadcast channel number; Battery power; broadcast channel type; area switching;
TK/ Emergency (orange)	Short Press	Non-functional; Emergency alarm; Cancel emergency alarm; Voice control; Power switch; Steady state monitoring [Simulation]; Steady cancel mute [Simulation]; Scanning; (DMR); one-click call 4 (DMR); broadcast local ID (number); broadcast channel number; broadcast power; broadcast battery power; broadcast channel type; area switching;
	Long Press	No function; emergency alarm; cancel emergency alarm; voice control; power switching; steady state monitoring [simulation]; transient monitoring [simulation]; steady state cancel squelch [simulation]; transient cancel squelch [simulation]; Network; One-key call 1 (DMR); One-key call 2 (DMR); One-key call 3 (DMR); One-key call 4 (DMR); Broadcast local ID (number); Broadcast channel number; Battery power; broadcast channel type; area switching;

Functional key

Non-functional

No function programmed(Invalid key, error beep)

Emergency alarm

Pressing this button allows the user to initiate an emergency alarm, which is a typical top key function. (Only short keys are supported, long keys must be associated with emergency alarm off)

Cancel emergency alarm

Pressing this button allows the user to stop an emergency alarm, which is a typical top key function. (Only supports long key, short key must be associated with emergency alarm on)

Steady state (analog)

If not automatically reset, press the key during receive. Press the key again to exit the monitor state.

Steady Cancel Squelch(analog)

Press key to disable noise squelch when squelch is open.
Press again to cancel and exit noise squelch.

Transient Cancel Squelch (analog)

Press to disable noise squelch when in transient squelch mode.
Release key to exit noise squelch.

Scanning

Press this button to enable or disable the scan function.

When scan is enabled, a beep will sound and the LED will flash green to indicate that the radio is in scan. Pressing the scan key again will result in two beeps to indicate scan mode was exited.

One Key calling 1-4(DMR)

One key calling function including SMS, Voice call.Operation:
To enable the feature, press the programmed key, then hold the PTT to launch the call.

Digital Channel Information

Function: Set digital channel digital protocol related parameters

Local number: The unique unit identifier used to identify an individual radio / radio user.

Group Call Timer: Maintains group call for the period of the timer for the group call users.

Private Call Timer: Maintains the private call for the period of the timer so the two units in the call do not drop out of private call until timer expires.

Transmit Pre-carrier Time: The transmitter carrier period before data or control information is sent to insure following information will be sent properly. It is to insure that other receivers have been captured before data is sent. It should be carefully set to support the needs of the system since it does consume channel resources. For example, time may be extended to insure scanning radios stop on channel.

Voice delay: This parameter defines the overall voice delay when the transceiver initiates voice communication

Time out timer(TOT)

Ensures that a channel is not used for an extended period that may consume resources and cause damage to the radio.

Timeout: The maximum amount of time allowed for continuous transmit. The radio will emit a local warning tone and will stop transmit when programmed time is met.

Early warning time: A pre-alert tone may be set to tell the user that the timeout time is about to be met. The alert will sound locally.

Retransmission time: This is the time set in programming that denotes the period from when the time out timer expires to when the user may transmit again. The radio will not be able to transmit until this time expires. Pressing the PTT will sound a warning tone.

Reset time: If the PTT is released before the timeout timer expires, the timer restarts the count once the PTT is pressed again.

Single call, Group call, All call

Single Call (private / individual call)

A call made by one user to another user.

Group call

A group call is made by one user to many users in the same group.

All call

A user makes a call to All users. All Calls are special groups that encompass all the users on a channel. It is considered a high level call meant for special uses and users. The All Call group ID is 16777215.

CTCSS/ CDCSS

CTCSS features:

CTCSS is sub-audible signaling used in analog operation to limit users to those with matching signaling. Reduces interference on a channel by selectively opening the radios audio gate.

CDCSS features:

CDCSS uses digital signaling in analog operation to limit users to groups with like signaling.

Tail Tone Elimination (squelch tail)

Used to stop the noise heard in a receiving radio when a transmitting radio stops transmitting by reversing the phase of the analog sub-audible signaling.

Power

Power level defines the RF output level emitted by the radio in transmit.

The power level should be set for the appropriate use to insure range, call quality, and battery life.

Value range: low power / high power

Default: low power

Power level table

Power level	Power(W)
High power	UHF 4W/VHF 5W
Low power	1W

Digital mode setting

Receiving Groups List

This feature allows users receive several different groups calls on one Digital Channel

Value Range: Group Call List 1- Group Call List 32

Default: Group Call List 1

Transmitting Groups List

Select the people you want to call from the contact list.

Value Range: Contact list 1- Contact 512

Default: Contact Call List 1

DMR

DMR uses TDMA technology which allows two simultaneous conversations with in a 12.5kHz Channel without any interference.

TDMA Direct Mode

Under TDMA direct mode one channel allows two simultaneous conversations. Every unit of one group has to use the same Time division which can avoid interference.

Operation

This feature has been turned on via programming software. After this feature been turned on, switch to Digital channel of TDMA select mode manually or turn on the unit at the Digital channel of TDMA select mode, which can enter TDMA Direct Mode.

Safety information

This manual provides you with safety instructions for the DELTA portable two-way radio.



Operation and Electromagnetic Exposure

Press PTT, hold the radio in a vertical position from 2.5 to 5.0 cm (1 to 2 inches) away from lips. Insure that the antenna is at least 2.5 cm away from your head and body when transmitting.

Electromagnetic Interference (EMI) / Electromagnetic Compatibly (EMC)

All electronic devices are subject to and may be affected by EMI unless proper compatibility design and testing have been accomplished. Radios should be powered off if unsure of EMI / EMC effects. Radios should be powered off aboard aircraft and the user shall adhere to the any and all airline requirements for RF emitters.

Operation warning

Radios including mobiles and portables shall not be mounted permanently or temporarily in areas of vehicles that use air bag safety restraint systems. Placing devices on or near air bags during deployment pose a safety hazard to the occupants of the vehicle.

Environment with explosion risk

Radios shall be powered off when in environments that pose an explosion risk unless the radio has received FM or Cenelec approval with certificate. In such environments, a small spark may lead to an explosion, fire, damage and death.

In the blast area or area with detonator

Radios shall be powered off near to and within an blasting area where detonators or other explosive materials are in use or stored.



Operation instruction

Damaged antenna

Damaged antennas shall be replaced. Exposure to the metallic portions of a damaged antenna can lead to burns.

Battery

Batteries shall not be changed or charged in explosive risk environments. Minor flames and / or sparks can lead to a explosion.

Any metal conductor, such as jewelry or keys, touching the battery contacts may lead to a short circuit condition that may result in a fire or burn. Care should be exercised to insure that the battery contacts are not allowed to touch other objects.

Radio's maintainance

- 1.Chemicals such as alcohol, cleaning fluids, and petroleum based products will damage the radio surfaces.
- 2.Do not pick up the radio using the antenna or purposely stress the housing and belt clip.
- 3.Please close the dust proof cover to protect the Microphone/ speaker jack while not using accessory.
- 4.Clean the surface of the radio with only a damp cloth using water. Insure that none of the water enters the radio case.
- 5.Unrecognized accessories may damage the radio and in this case our warranty will be unavailable.